



Float Switches

“20A400” Series Junior M-Navigator Float Switches

Features & Benefits

- Durable Polypropylene Body Foam Filled Construction
- Mercury Type Switch Actuation
- Wide Angle (90° Operating Range)
- Pump Duty Rated
- Rated ½ hp @ 120VAC, 1 hp @ 240VAC (13 amps)
- Available in Pump Up or Pump Down Configurations
- Available w/External Weight, SST Pipe Clamp or Cable Tie
- Multiple Cord Lengths Available

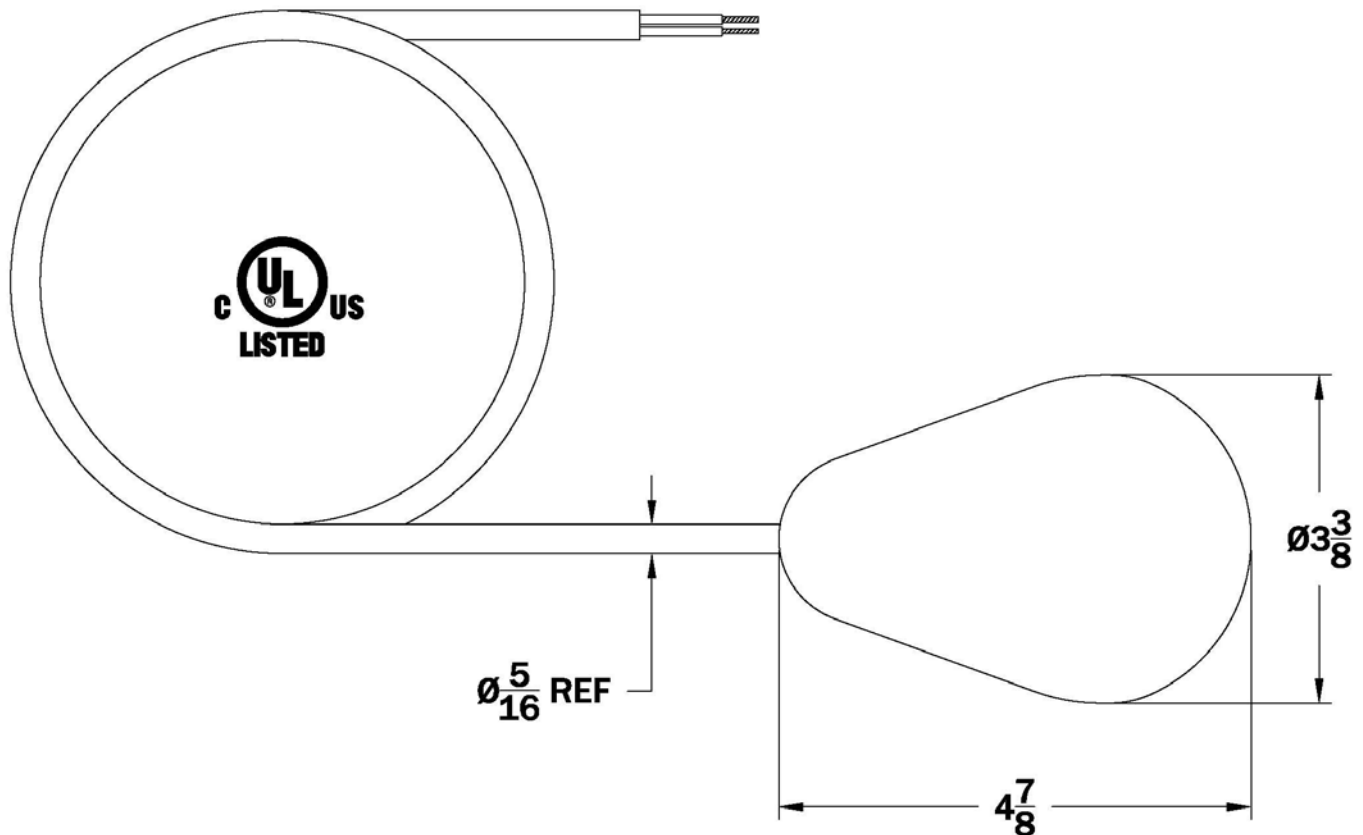

*Note: Consult the factory for other available options. Not Recommended for Potable Water Applications.



Septic Products, Inc. 1378 Twp Rd Ashland, Ohio 44805 Ph: (419)282-5933 Fax: (419)282-5943

Float Switches

“20A400” Series Junior M-Navigator Float Switches

Typical Mounting

