



ALARM SYSTEMS

“Observer 400” Series Indoor/Outdoor Alarm

Features & Benefits

- NEMA 4x Thermoplastic Enclosure
- Large Alarm Condition Indicating Light
- Audible Horn rated 85db @ 10'
- Alarm Test-Normal-Silence switch
- Automatic Alarm Reset
- Auxiliary Dry Alarm Contact
- Easy to Access Terminal Block
- Repairable Design
- Includes 15' Mechanical Alarm Float & mounting tie strap
- Suitable for Indoor or Outdoor Use
- Available Circuit for Pump Connection (115VAC-1PH Only)
- Two Year Limited Warranty
- Available in both High Water & Low Level Alarm versions



Dimensions

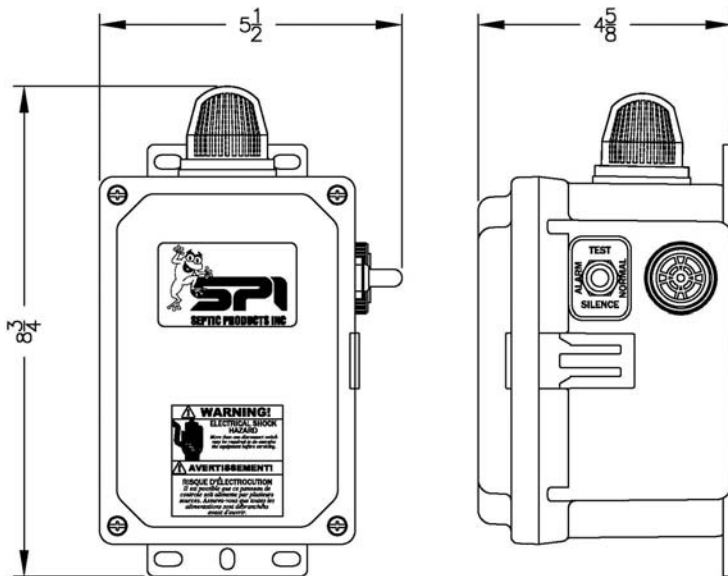

(Standard Observer 400 Shown)

*Note: Consult the factory for other available options.

“Observer 400” Series Indoor/Outdoor Alarm

Typical High Water Alarm Installation

